

Air Purifier

User Manual

Model: LY-PS1



Please read the instruction manual carefully and keep it at a safe place for future reference. When the appliance is given to another person the instruction manual should be passed to that person, too.

Quick and easy access to all important information with QR codes

The following QR codes provide you with quick and easy access to all important information about your **Atemglanz air purifier**:

- **First QR code:**
Here you can download the user manual as a PDF file.
- **Second QR code:**
This takes you to our **information product**, a **video coaching** session that is available free of charge when you purchase an air purifier, which clearly explains how to use the air purifier and its functions.

Product Information & Support

Detailed **product information**, information on **spare parts**, **accessories**, and **manufacturer warranties** can be found in this user manual.

For fast and personalized support, you can contact us at any time by email:

✉ info@atemglanz.de

What are QR codes?

QR codes (QR = Quick Response) are graphic codes that can be scanned with a smartphone camera. They lead directly to websites, documents, or videos, for example.

The advantage:

No more tedious typing of web addresses - just scan and get the information you need right away.

How scanning works

To scan a QR code, you need:

- a smartphone with a camera
- a QR code scanner installed (usually already integrated into the camera app)
- an active internet connection*

QR code scanners are usually available free of charge from your smartphone's app store.



User manual as PDF
in German and English



Video-Coaching

* Depending on your tariff, costs may be incurred when using the Internet connection.

General information

Read and keep the user manual



This user manual belongs to this air purifier. It contains important information on commissioning and handling.

Read the operating instructions carefully, especially the safety instructions, before using the air purifier. Failure to follow these operating instructions may result in serious injury or damage to the air purifier.

Keep the user manual for future reference. If you pass the air purifier on to a third party, be sure to include the user manual.

Explanation of symbols and further information

The following symbols and signal words are used in this user manual, on the device, and/or on the packaging, or serve to provide additional information.



Read and follow the user manual!

Important warnings are marked with this symbol.



WARNING!

refers to personal injury

Note!

refers to property damage



information is marked with this symbol.



This symbol indicates special regulations for the disposal of old devices (see chapter "Disposal").

Protection class: IPX0

This means that there is no protection against water.

Safety Intended use

The device was developed to improve indoor air quality. It serves to reduce particles, dust, pollen, and other airborne contaminants. The air purifier is intended for private use only and is not suitable for commercial use or operation in heavily polluted or industrial environments. Any other use or modification of the device is not in accordance with its intended purpose and is strictly prohibited. No liability can be accepted for damage caused by improper use or incorrect operation. This product is classified as a device that is accessible to the general public.

Safety instructions



Read and observe all of the safety instructions listed below. Failure to do so may result in a significant risk of accidents and injuries, as well as damage to property and equipment.

Hazards for children and persons with limited abilities

- This appliance can be used by children aged from 8 years and above under supervision.
- This appliance can be used by persons with reduced physical, sensory or mental capabilities or lack of experience and knowledge if they have been given supervision or instruction concerning use of the appliance in a safe way and understand the hazards involved.
- The appliance is only to be used with the power supply unit provided with the appliance.
- Children should not play with the appliance. Children do not recognize the dangers associated with electrical appliances. Therefore, use and store the appliance out of the reach of children under 8 years of age. Do not let the power cord hang down so that it cannot be pulled.
- Cleaning and maintenance should not be carried out by children under 8 years of age without supervision.
- Keep children under 8 years of age away from the device and the connection cable.
- Do not allow children to play with the packaging film. They could get caught in it and suffocate. – **Risk of suffocation!**

Dangers when handling electrical appliances

- Only connect the device to a properly installed grounded outlet with a mains voltage as specified on the type plate.
- If the power cord is damaged, it must only be replaced by a specialist workshop designated by the manufacturer in order to avoid the risk of injury, accidents, and damage to the device.
- Ensure that the power outlet is located near the device and is easily accessible so that the device can be quickly disconnected from the power supply in the event of a malfunction.
- Repairs may only be carried out by authorized specialist workshops. Devices that have not been repaired properly pose a risk to the user. Please contact support directly at info@atemglanz.de
- Do not leave the device unattended during operation to avoid accidents.
- To avoid accidents, never connect several household appliances to the same grounded outlet at the same time (e.g., via a 3-way power strip).
- Never immerse the device in water and do not use it outdoors, as it must not be exposed to rain or other moisture. **Risk of electric shock!**

- If the device does fall into water, first unplug the power cord and then remove the device! Do not use the device again; have it checked by an authorized service center first. This also applies if the power cord or the device is damaged or if the device has been dropped. **Risk of electric shock!**
- Always unplug the power cord when the device is not in use and before cleaning or in case of malfunction! Never pull on the power cord! **Risk of electric shock!**
- Ensure that the power cord or the device is never placed on hot surfaces or near heat sources. Lay the power cord so that it does not come into contact with hot or sharp objects. **Risk of electric shock!**
- Never kink the power cord or wrap it around the device, as this can lead to a cable break. **Risk of electric shock!**
- Do not use the device if you are standing on wet ground or if your hands or the device are wet. **Risk of electric shock!**
- Never open the device except to change the filter and never attempt to reach inside with metal objects. **Risk of electric shock!**

Risks associated with operating the air purifier

- Do not cover the device during operation. Ensure sufficient space and a safe distance from walls, ceilings, and other objects.
- Ensure that there is at least 20 cm of space around the device. A distance of at least 30 cm must be maintained above the device.
- Ensure that the air inlet and outlet are not covered. Therefore, do not place any objects on the air outlet or in front of the air inlet.
- Ensure that no foreign objects fall into the device through the air outlet.
- Do not insert any objects into the air inlet or outlet openings or into the device. Also ensure that no loose objects such as curtains or drapes, or even long hair, ties, etc. get into the ventilation openings. They could be sucked in by the air flow.
- No objects may be placed on the device. Do not sit or stand on the device. Do not place any objects on the device.
- The device is not a substitute for adequate ventilation, regular vacuuming, or the use of an extractor hood or fan during cooking.
- Always use the device on a dry, stable, level, and horizontal surface.
- Do not place the device directly under an air conditioner to prevent condensation from dripping onto the device.
- Be careful not to put your fingers or other objects in the air outlet or inlet to prevent injury or damage to the device. Do not use the device after using insect repellent incense or in places where the air is contaminated with oil residues, burning incense sticks, or chemical vapors.
- If using an extension cord, it must comply with the applicable safety regulations.
- To avoid hazards, always unplug the power cord from the grounded outlet when not in use.
- Please note that in addition to switching off the device, you must also unplug the power cord from the grounded outlet to completely disconnect the device from the power supply.
- Make sure that you place the device on a level, stable, non-slip, and dry surface. Do not place the device directly against a wall or under a wall cabinet or similar. The device requires sufficient space above and to the sides.
- Do not use the device near gas-powered appliances, heaters, or open fireplaces.
- Only use original accessories! Using non-original accessories increases the risk of accidents. We accept no liability for accidents or damage caused by non-original accessories. Using third-party accessories and any resulting damage to the device will void any warranty claims.
- Do not expose the device to vibrations or shake it.
- Never use harsh or abrasive cleaning agents or sharp objects for cleaning.

- **The filter inside the device is packed in an additional plastic bag. Please remove this plastic bag before using the device.**
- The device does not remove carbon monoxide (CO) or radon (Rn). It cannot be used as a safety device in accidents involving combustion processes and hazardous chemicals.
- Never operate the device with wet hands or immerse the power cord in water!
- Unplug the power cord before cleaning, maintenance, or prolonged periods of non-use.
- The device must not be used in bathrooms, outdoors, or in damp environments. Avoid contact with water or other liquids.
- Only change the filter when the device is switched off and disconnected from the power supply.
- Only use suitable replacement filters.
- Dispose of used filters in accordance with local regulations.
- If unusual noises, odors, or vibrations occur, switch off the device immediately, unplug it, and contact customer service.
- Do not leave the device running unattended near small children or pets.
- Do not attempt to repair the device yourself! Do not open the device – **risk of electric shock!**
- Do not use aggressive cleaning agents or solvents to clean the housing.
- Unplug the power cord from the outlet if a malfunction occurs during operation or during a thunderstorm. Always pull on the power cord, not the cable.
- Only use and store in closed rooms.
- Never cover the device during operation.
- Only connect the product to an easily accessible power outlet so that you can quickly disconnect it from the power supply in the event of a malfunction.

Additional warnings

- Cleaning and maintenance by the user must not be carried out by children without supervision.
- The device may only be used with the power supply unit (cable and adapter) supplied.
- This device can be used by children aged 8 and above under supervision.
- This device may be used by persons with limited physical, sensory, or mental capabilities, or lack of experience and knowledge, if they are supervised or have been instructed in the safe use of the device and understand the hazards involved.
- Precautions must be taken when performing user maintenance. These are explained in detail in the maintenance chapter.
- Precautions must be taken when installing the device. These are explained in detail in the chapter on installing the device.
- The chapters on maintenance and installation of the device contain instructions and information on cleaning and other maintenance of the device by the user, as well as instructions on disconnecting the device from the power supply before cleaning or other maintenance work. (IEC 60335-2-65).
- This appliance can be used by children aged from 8 years and above and persons with reduced physical, sensory or mental capabilities or lack of experience and knowledge if they have been given supervision or instruction concerning use of the appliance in a safe way and understand the hazards involved.
- This appliance can be used by children aged from 8 years and above under supervision.
- This appliance can be used by persons with reduced physical, sensory or mental capabilities or lack of experience and knowledge if they have been given supervision or instruction concerning use of the appliance in a safe way and understand the hazards involved.
- This appliance is only to be used with the power supply unit provided with the appliance.

Product Launch Setup and assembly

This air purifier powerfully removes dust and smoke, making it suitable for places with high levels of smoke, dust, pollen, and other fine dust pollution, such as indoor spaces, smoking areas, living rooms, etc. It reduces the risk of health hazards caused by secondhand smoke and smog, protecting your health and that of your family.

The device was developed to improve indoor air quality. It serves to reduce particles, dust, pollen, and other airborne contaminants. The air purifier is intended for private use only and is not suitable for commercial use or operation in heavily polluted or industrial environments.

This air purifier is equipped with a multifunctional filter that efficiently removes fine dust from the air and effectively eliminates PM2.5 fine dust, formaldehyde, and odors (smoke) to provide you with clean and fresh air to breathe.



Multifunctional filter

It adsorbs smoke, pollen, and dust and filters bacteria from the air. Thanks to its antibacterial effect, it cleans the air deep down and effectively removes fine dust (PM 2.5). It effectively removes formaldehyde, TVOC, and unpleasant odors (smoke) from the air.

Components

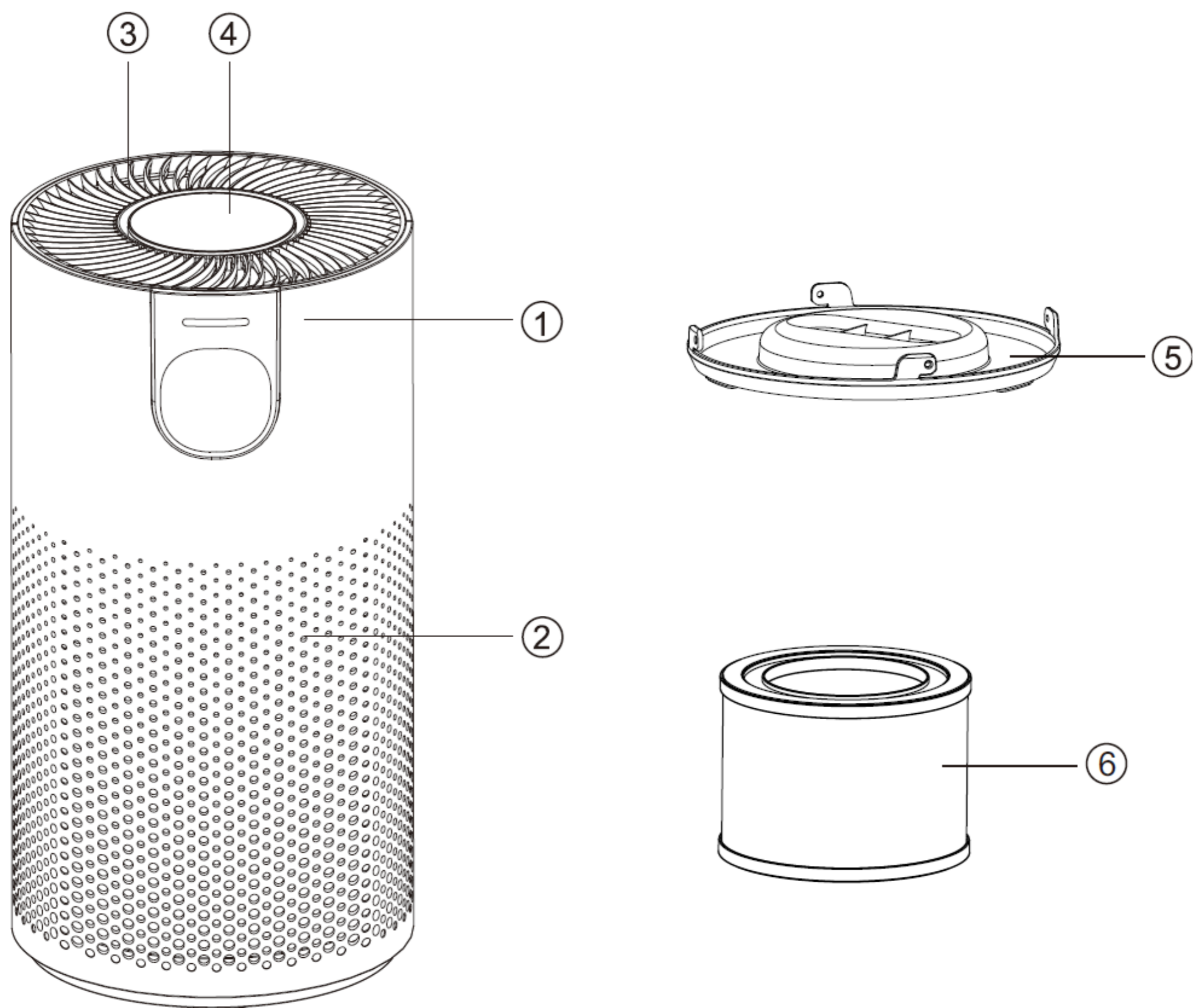

Components Overview

1. Housing
2. Air inlet
3. Air outlet
4. Control panel
5. Filter cover
6. Multifunction filter

Before first use

After unpacking, please check the device for completeness and any transport damage to avoid hazards. If in doubt, do not use it, but contact our customer service department. The service address can be found on the warranty card.

Your device is packaged to protect it from damage during transport.

- Carefully remove the device from its sales packaging.
- Remove all packaging materials.

Important note: The filter inside the device is packaged in an additional plastic bag. Please remove this plastic bag before using the device.

- Remove the protective film from the control panel.
- Clean the device and all accessories of any packaging dust residue, as described in the chapter “Maintenance, cleaning, and care.”

Preparation for use

Remove the multifunction filter

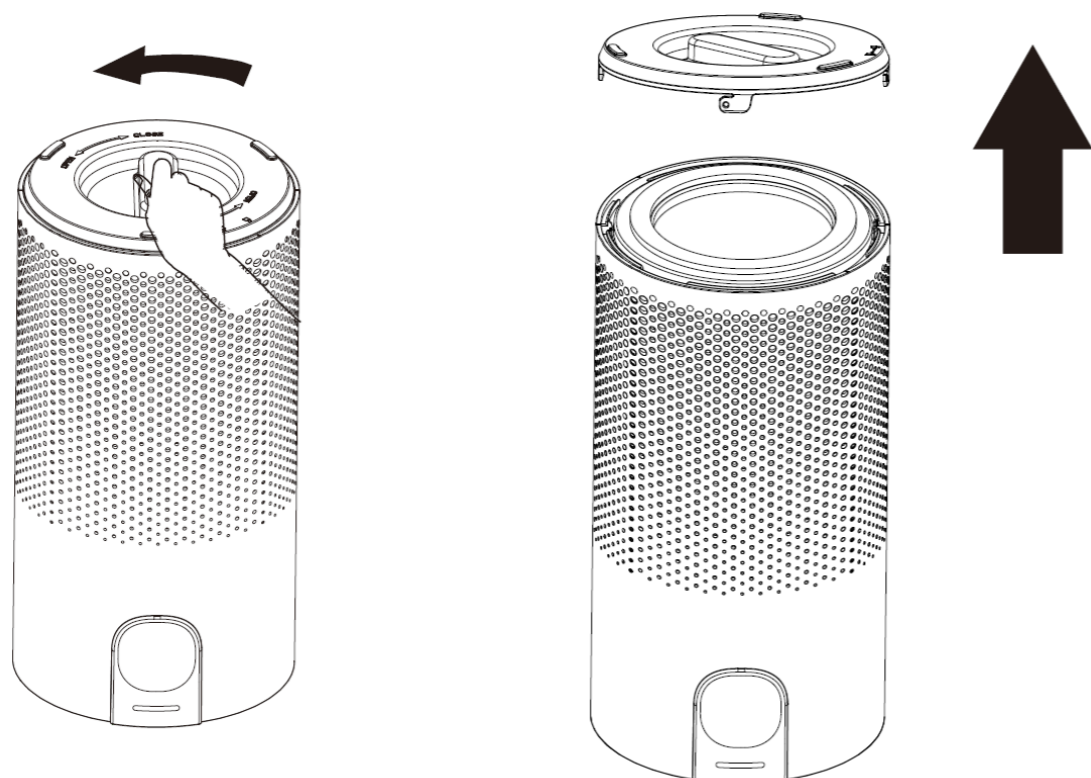

1. Grasp the handle on the base and turn it counterclockwise to unscrew the base.

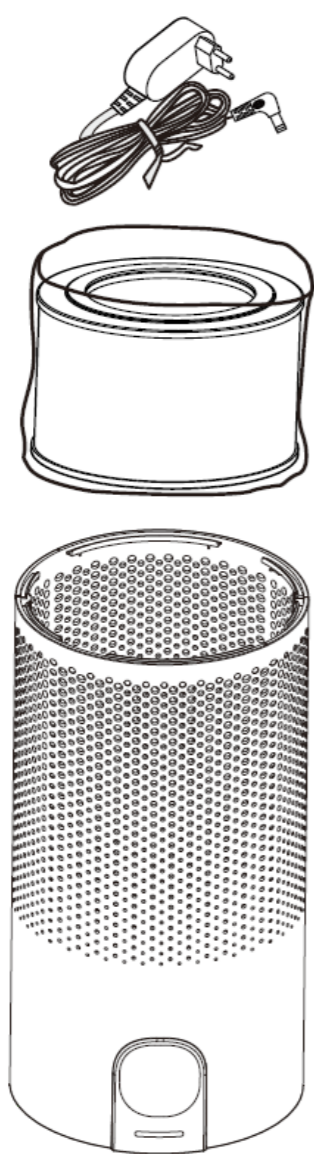

2. Remove the filter and adapter from the product.

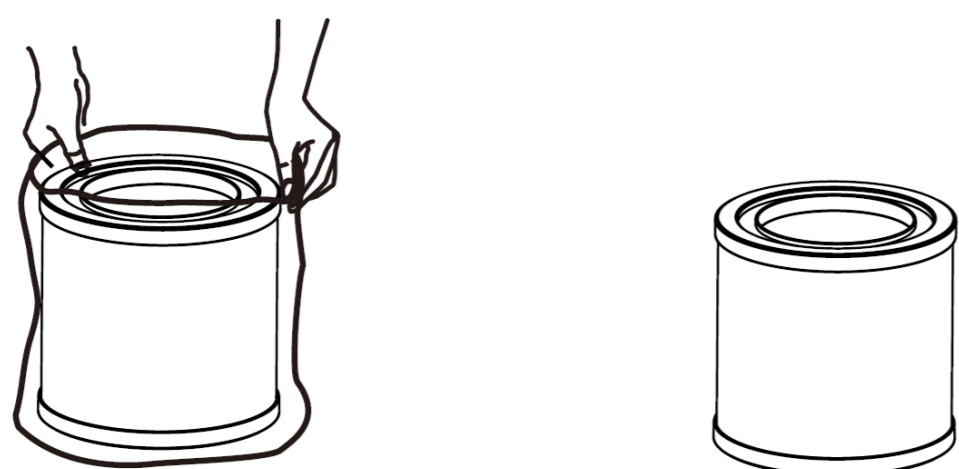

3. Remove the filter from the plastic bag.

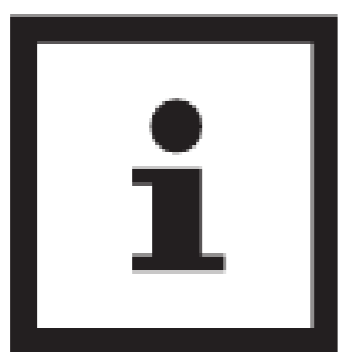

As the multifunction filter is a wearing part, it is not covered by the warranty for the entire device. Please ensure that the multifunction filter is in perfect condition before removing the protective packaging.

Preparation for use

Installing the multifunctional filter

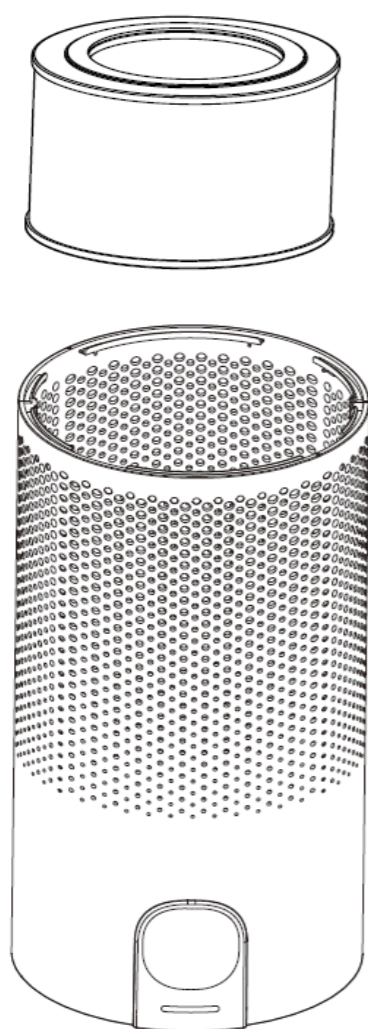

1. Install the multifunction filter.

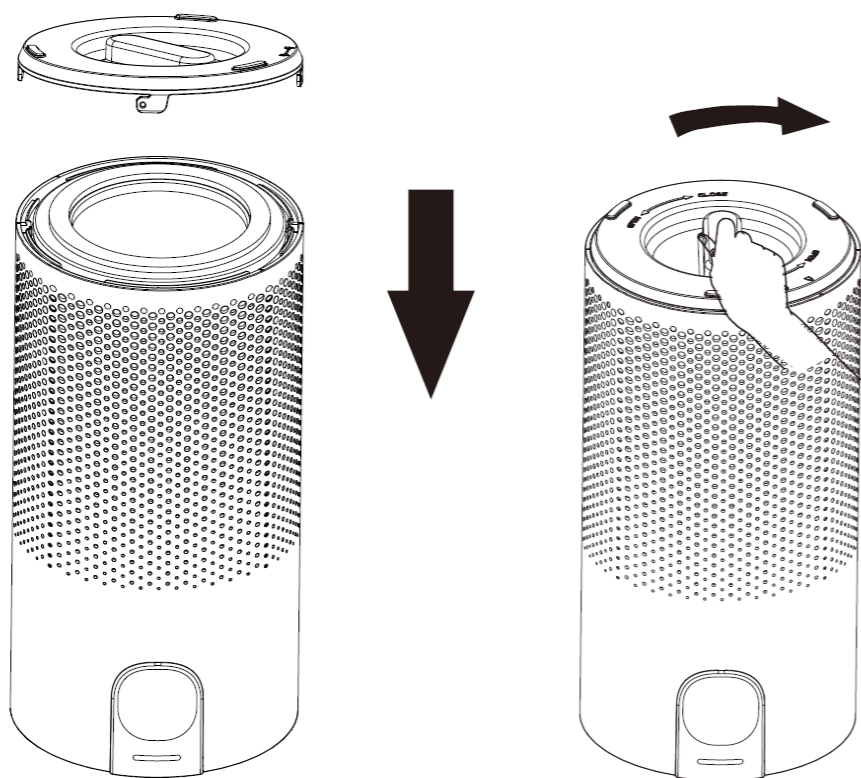

2. Insert the base, hold the handle firmly, and turn it clockwise to tighten the base.



Please do not use the air purifier if the multifunction filter is not installed.
Be sure to turn the bottom cover clockwise until you hear a distinct click. This indicates that the bottom cover is locked. Turn counterclockwise to unlock the bottom cover.

Preparation for use

Turn on the power

Place the air purifier on a flat surface and then plug it into the power outlet.

The product may only be used with a 100-240V and 50/60Hz power outlet.

Before plugging in, please ensure that your hands and the plug are dry. If your hands or the plug are wet, please wipe them dry before plugging the plug into the power outlet.

After switching on, the indicator light on the control panel flashes briefly once. Each time the button is pressed, a “beep” sound is emitted.

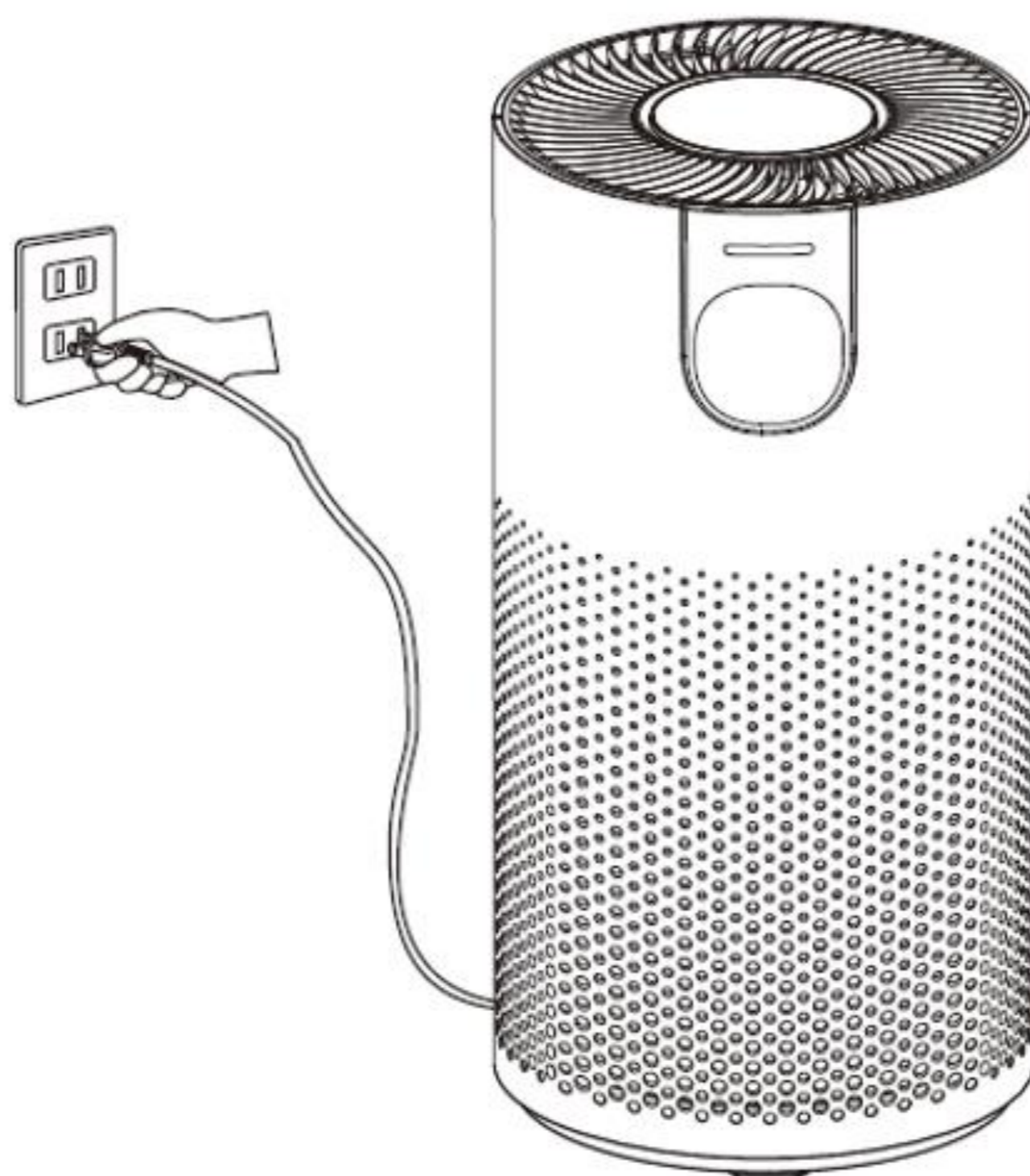

Please close doors and windows during use.

If the air quality does not improve after the air purifier has been running for a certain amount of time, please open doors and windows to allow for ventilation. (In extreme environmental conditions)

Control Panel

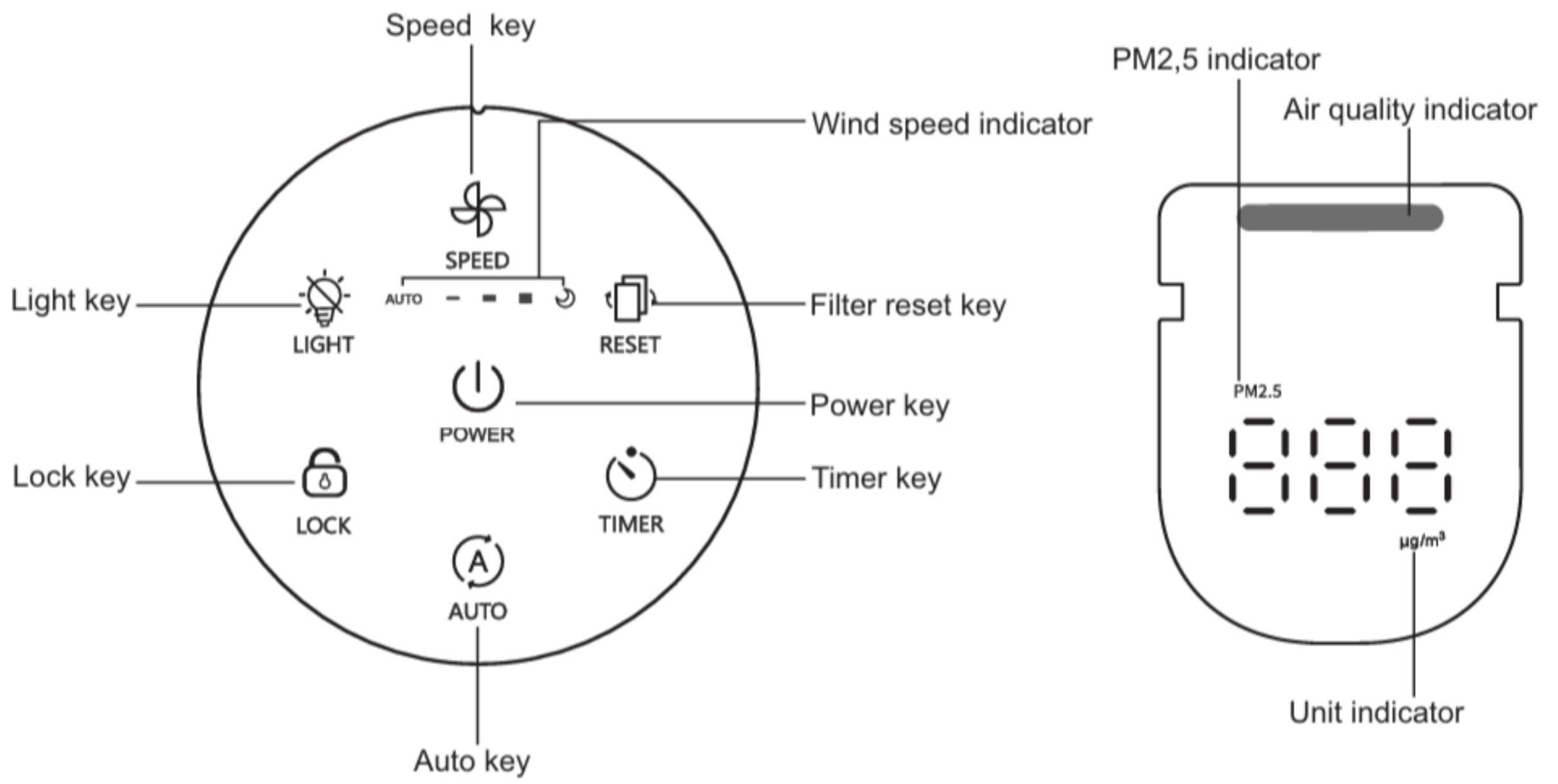

PM2.5 and air quality indicator

PM2.5 refers to particulate matter with a diameter of 2.5 micrometers or less. These particles are invisible and can remain suspended in the air for long periods of time.

The PM2.5 value indicates the current level of particulate matter pollution and is often used to assess air quality. Elevated PM2.5 levels can affect breathing comfort and general well-being. Monitoring the PM2.5 value helps users understand changes in air quality and the effectiveness of air purification measures.

A built-in sensor detects fine dust in the air that is drawn in. The device calculates the particle mass concentration ($\mu\text{g}/\text{m}^3$) and displays the PM2.5 value in real time.

PM 2.5 air quality reference

PM2.5 ($\mu\text{g}/\text{m}^3$)	Air quality	Light
0-50	Excellent	Green
51-100	Good	Blue
101-150	Slightly polluted	Yellow
>150	Heavily polluted	Red

*Reference values commonly used to assess indoor air quality.

Overview of the filtration system

The air purifier uses a three-stage filter system for air purification.



A. Pre-filter

- Catches large particles such as dust, lint, fibers, hair, and animal hair.
- Maximizes the filter's service life by protecting it and has a microbacterial effect.

B. Main filter

- 99.97% filtration efficiency for 0.3 μm small to medium-sized particles in the air, including pollen, dust, smoke, and animal hair allergens.
- The main filter consists of a highly efficient HEPA 13 filter. HEPA stands for High Efficiency Particulate Air.

C. Activated carbon filter

- Has a physical effect on odors.
- Filters compounds such as CO₂, benzene, ammonia, hydrogen sulfide, and volatile organic compounds (TVOC*).

*This filter system removes small and large particles such as dust, lint, fibers, hair, pet hair, etc., and absorbs 0.3 μm particles such as pollen, dust, smoke, pet hair, and allergens. It also eliminates odors and removes most viruses and bacteria in solid form from the air in the recommended enclosed spaces. Air purifiers cannot prevent the spread of infection by infected individuals, nor do they remove bacteria and viruses from surfaces. Therefore, please use this air purifier in combination with other preventive measures.

*TVOC (total volatile organic compounds): Gaseous substances released from household materials, furniture, and cleaning agents, such as formaldehyde, benzene, etc.

Instructions for use

Start



Light on



Plug the power cord into the power outlet and press the on/off switch to start the device. In standby mode, press the on/off button to start the device. The air purifier will start working in automatic mode. The automatic mode indicator will light up and the air quality indicator will flash alternately in red, yellow, blue, and green for 30 seconds.

In standby mode, follow the previously selected operating mode to restart the machine. If you are in any operating mode other than “standby mode,” press the button. The air purifier will then interrupt the current mode, switch to standby mode, and the operating indicator will light up halfway.

Wind speed



Light on

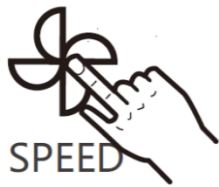

In operating mode, press the speed button. The wind speed will then cycle through -, =, =, and ㄩ. At this point, the corresponding wind speed indicator will light up.

When the wind speed is set to sleep mode, the sleep indicator light and the switch indicator light are half lit, and all other lights are off.

Auto



Light on



In operating mode, the user can start or stop the automatic function by clicking this button.

Light



Light on



In operating mode, the user can switch the light function on or off by clicking this button.

Timer



Light on



In operating mode, press the “Timer” button to start the time-controlled switch-off function. The time can be set to 1-2-3...24 (h). To cancel the timer, the corresponding indicator light illuminates.

After the planned shutdown time has elapsed, the timer can be canceled by pressing and holding the timer button for three seconds. Pressing the on/off button will shut down the device immediately.

Child safety lock



Light on

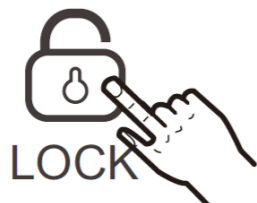

In operating mode, the user can press and hold the lock button for 3 seconds to activate or deactivate the lock function. The indicator light on the lock button illuminates.

Multifunctional filter reset





Light on



The internal timer calculates the cumulative operating time. When the filter light flashes red (at each start-up), a five-tone buzzer reminds the user to change the filter. (The timer time was calculated based on simulation tests in the laboratory and may differ from the actual usage time. Please replace the filter in good time if the cleaning performance deteriorates.)

- After changing the filter, press and hold the “RESET” button for 3 seconds. A buzzer will sound and the time setting will be reset.
- As long as the filter life has not expired, the user can replace the filter, press and hold the reset button for 5 seconds, and the buzzer will sound twice to remind them to reset it in time.
- When the filter indicator flashes, please replace the filter in time.

Packing list

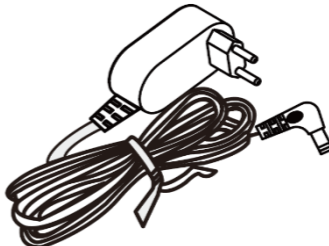
Packaging position	Packaging of the main motor			Comments
	Form	Main motor of the air purifier	User Manual	
Quantity	1	1	1	
				
				<u>The cable length is 1.5 m.</u>

Specification parameters for air purifiers

Model name	LY-PS1
Rated current	1A
Rated voltage	24V
Power	20W
Protection class IP	IPX0

Specification parameters for power adapters

Model	LY024AHV240100
Supply voltage	AC100-240V
Frequency	50-60Hz
Input current	1.0A
Output voltage	DC24V
Output current	1.0A
Protection class	II

Maintenance

Maintenance instructions

Before performing maintenance work, the power plug must be disconnected and the power supply disconnected.

Cleaning

Wipe the machine housing and control panel with a dry, soft cloth. Please do not use a cloth with a hard texture for wiping, as this may damage the surface. Please do not use a dry cloth to touch the power cord, as this may cause residual water to remain on the plug surface and result in an electric shock. Please use a neutral cleaning agent and refrain from using cleaning powder, alkaline cleaning agents, thinners, bleach, alcohol, and gasoline to clean the machine housing.

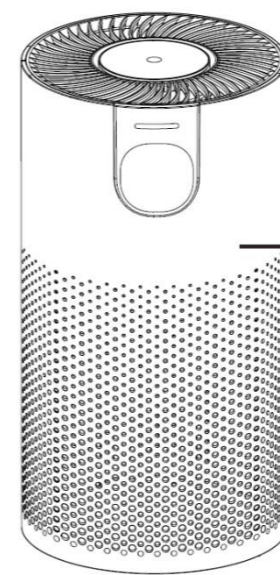

Care

Multifunction filter

- The multifunction filter cannot be washed with water.
- The multifunction filter is a consumable item and is not covered by the warranty.
- The brush nozzle or crevice nozzle should be padded with paper.

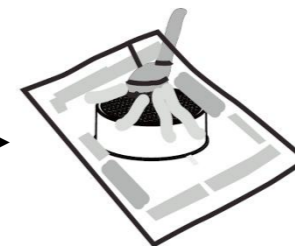
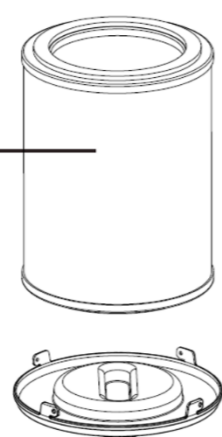

Notes

Please do not operate the device while the multifunction filter is removed. (This will disable the dust separation function and the inhaled dust may cause sensor errors.)

Reference date for filter replacement

Multifunction filter:

When the filter change indicator light flashes, which occurs approximately every **3,000 hours**, the filter should be replaced.

Condition:

The product is in use 24 hours a day and is subject to normal operating conditions. If the operating environment is heavily contaminated, please shorten the replacement interval according to the practical situation.

The filter replacement interval may vary depending on the operating environment and method of use. Therefore, please replace the filter in a timely manner if performance is unsatisfactory.

After replacing the filter, press and hold the filter reset button for 3 seconds. The filter replacement indicator light will turn off, indicating that the reset is complete.

Please dispose of the used filter as non-combustible waste.

Troubleshooting

The problems that may occur when using the machine are listed below. If you are unable to resolve the problem using the following information, please contact your seller support by email at info@atemglanz.de or directly contact your Amazon seller support.

Problem	Possible solution
The filter indicator flashes for a long time.	You ignored the filter change warning. When the filter warning light started flashing, you did not change the filter in time. You must change the filter and press and hold the filter reset button for 3 seconds. After resetting, the warning light will go out.
There is no air at the air outlet.	The product is not connected to the power supply. Please plug the power cord into the wall outlet to turn on the product.
The product has been in use for a long time, but the air quality has not improved significantly.	Certain filters may not be included with the product. Please ensure that the filters are installed correctly and in the correct order. Start with the innermost filter: multifunction filter – base. The humidity in the room is too high, causing condensation to form. Please do not place the product in areas with high humidity, such as bathrooms or toilets. The barrier around the product may impair its cleaning performance (see notes). The room in which the product is located is too large. The recommended room size for this product is 20 m ² .
There is dirt in the air that is difficult to remove.	Please check whether the HEPA multifunction filter is dirty. If the situation has not improved after cleaning, please replace the multifunction filter.
The smell in the air is difficult to remove.	Is the product being used in a place with strong odors? If the product is used near cigarette smoke, frying, or other strong-smelling environments, odors may develop after a few weeks or months. In this case, please replace the multifunctional filter and ensure regular ventilation.

Calculation of applicable room area

The room area to be cleaned is calculated by multiplying the **CADR (Clean Air Delivery Rate)** value by 0.12. This method is based on an air exchange rate of approximately **2.5–3 air changes per hour**.

1. CADR (Clean Air Delivery Rate) is the industry standard measurement that indicates the practical cleaning speed of an air purifier for a specific room size.
2. The CADR value of this model is 180 m³/h, and it cleans the room 2.5-3 times per hour.

Electrical and Electronic Equipment

Information for private households in accordance with Section 18 (4) of the German Electrical and Electronic Equipment Act (ElektroG)

The German Electrical and Electronic Equipment Act (ElektroG) contains a large number of requirements for handling electrical and electronic equipment. The most important ones are summarized here.

1. Separate collection of waste equipment

Electrical and electronic equipment that has become waste is referred to as waste equipment. Owners of waste equipment must dispose of it separately from unsorted municipal waste. In particular, waste equipment does not belong in household waste, but in special collection and return systems.

2. Batteries and rechargeable batteries, as well as lamps

Owners of old appliances must separate old batteries and accumulators that are not enclosed in the old appliance, as well as lamps that can be removed from the old appliance without causing damage, from the old appliance before handing it in at a collection point. This does not apply if old appliances are sent for preparation for reuse with the involvement of a public waste disposal authority.

3. Options for returning old devices

Owners of old devices can return them free of charge as part of the return or collection options for old devices set up and made available by public waste disposal authorities to ensure that old devices are disposed of properly. Under certain conditions, it is also possible to return devices to distributors.

For distributors: The return must be free of charge when purchasing a new device of the same type. (1:1 return) Regardless of this, it is possible to return old devices to the distributor free of charge. The prerequisite for this is that the external dimensions are no larger than 25 centimeters and that the return is limited to three old devices per device type (0:1 return).

Retail: Distributors with a sales area for electrical and electronic equipment of at least 400 square meters are obliged to take back old electrical equipment. Food retailers with a total sales area of at least 800 square meters who offer electrical and electronic equipment several times a calendar year or on a permanent basis and make it available on the market are also obliged to take back old equipment.

Distance selling market: Distributors who sell their products using means of distance communication are obliged to take back waste equipment if their storage and shipping areas for electrical and electronic equipment are at least 400 m².

B2B manufacturers: In the case of B2B equipment, take-back does not have to be offered free of charge.

4. Privacy notice

Old devices often contain sensitive personal data. This applies in particular to information and telecommunications technology devices such as computers and smartphones. In your own interest, please note that each end user is responsible for deleting the data on the old devices to be disposed of.

5. WEEE registration number

We (Mario Kossel Sole Proprietorship and Atemglanz Brand) are registered with the stiftung elektro-altgeräte register (foundation for the registration of old electrical appliances), Nordostpark 72, 90411 Nuremberg, Germany, as a manufacturer of electrical and/or electronic equipment.

6. Collection and recycling rates

Under the WEEE Directive, EU member states are required to collect data on waste electrical and electronic equipment and submit it to the European Commission. On the BMUV website (<https://www.bmuv.de/themen/wasser-ressourcen-abfall/kreislaufwirtschaft/statistiken/elektro-und-elektronikaltgeraete>) you will find further information on this.

7. Meaning of the symbol “crossed-out trash can”

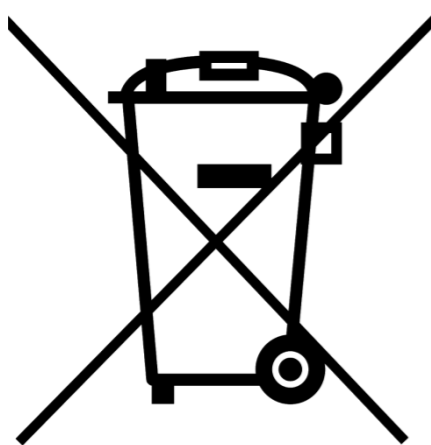

Within the EU, this symbol indicates that this product must not be disposed of with household waste. Old appliances contain valuable recyclable materials that should be recycled and not harm the environment or human health through uncontrolled waste disposal. Therefore, please dispose of old appliances via suitable collection systems or send the appliance to the place where you purchased it for disposal. They will then send the appliance for recycling.



Proper disposal of this product



When this device has reached the end of its useful life, please dispose of it properly. This and other electrical devices contain valuable, recyclable materials. Electronic waste can harm our environment if it is not disposed of properly. Please observe the applicable regulations of your local authority when disposing of electrical devices. Please find an authorized recycling center near you.

Contact options for customer support

Manufacturer:
Mario Kossel (Einzelunternehmung)
Mooswiesstrasse 12
8864 Reichenburg
Switzerland

Brand: Atemglanz ®
Contact: info@atemglanz.com
Item/model no.: LY-PS1
Product: Air purifier
Product description: Air purifier for household use